

Glow Plug Removal Tool, M10x1.0 (Art. 8699)

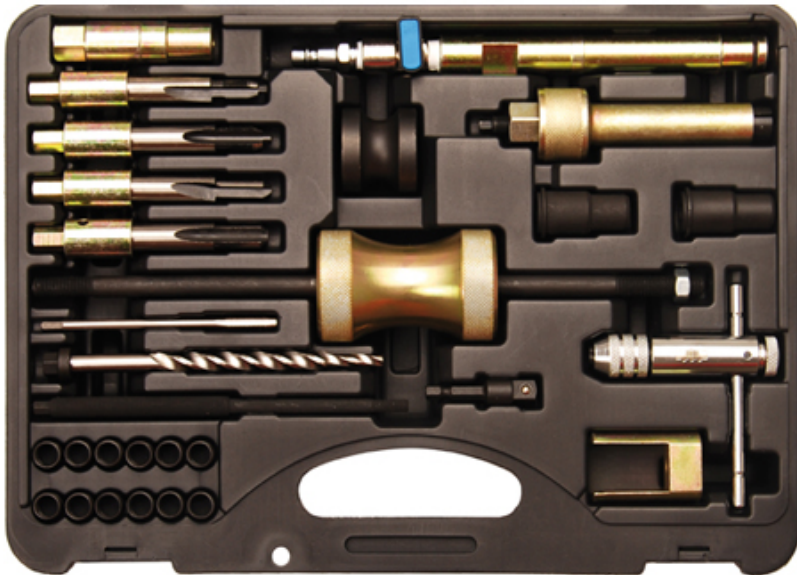

- ensures the correct removal of burned-in, corroded or broken-off glow plugs
- allows repairing of the glow plug retaining thread without removing the cylinder head
- defective original thread M10 x 1 is repaired by insertion of a new threaded sleeve
- includes:
 - puller and sliding hammer for removing of stuck and broken glow plugs
 - reamers for reaming of the defective thread
 - tap M10 x 1 and M12 x 1
 - centering sleeve for reamers and taps
 - special step drills and taps for removal of broken glow plugs
 - 12 thread repair sleeves M12 x 1 to M10 x 1
 - compressed air adapter
- suitable for Mercedes CDI-engines
OM 611, 612, 613, 628, 646 (not EVO), 647, 648

Technical modifications reserved - we are not responsible for issues while printing